

RS

TW 104.28 N/Ag 8Ω

1.1" Dome tweeter

Code ZH02800-8

Years of laboratory testing and listening, supported by sophisticated measurements, have led us to develop tweeters characterized by precise choices: RS tweeters use **silk domes**, a lightweight material with consistent characteristics that lends itself to various treatments to enhance its dynamic performance. The dome undergoes both internal and external treatments to create a mini-sandwich structure, preventing deformation. The **suspension** is treated with a rubber-based solution for increased stability and elasticity. The **voice coil** winding uses flat copper clad aluminum wire for maximum lightness and optimal magnetic gap fill; the former is made of aluminium. The neodymium **magnetic circuit**, is ventilated and the pole is covered with a **silver cap** to maintain consistent impedance at high frequencies, ensuring better amplifier interfacing. The tweeter features a rear **aluminium cup** designed for enhanced cooling radiation. This cup forms a **rear damped chamber**, reducing the tweeter's resonance at 500 Hz and enabling a cutoff frequency well below the crossover point. The volume created by the rear dome and its associated ducts is meticulously engineered to minimize resonances and is dampened with sound-absorbing material. This design reduces the impedance peak at the tweeter's resonance, allowing for simpler and less invasive crossovers, thereby optimizing overall sound quality. Every element of the tweeter design concurs in the quest for the purest sound, the ultimate target for RS.

- Treated silk dome
- Damping dome treatment
- Large roll surround
- 1.1" voice coil with aluminium flat wire and aluminium former
- Rear damped chamber for low resonant frequency
- Neodymium magnet circuit with silver shorting ring and damping material inside
- Ventilated top plate
- Aluminium flange

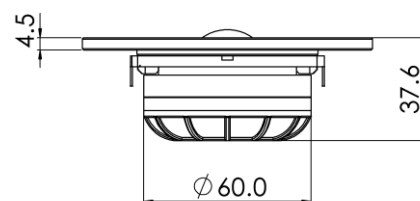
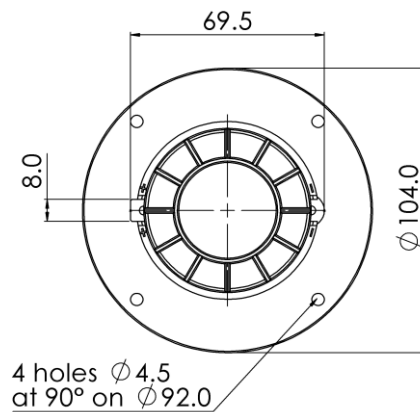

pura passione



TW 104.28 N/Ag 8Ω

1.1" Dome tweeter

Code ZH02800-8

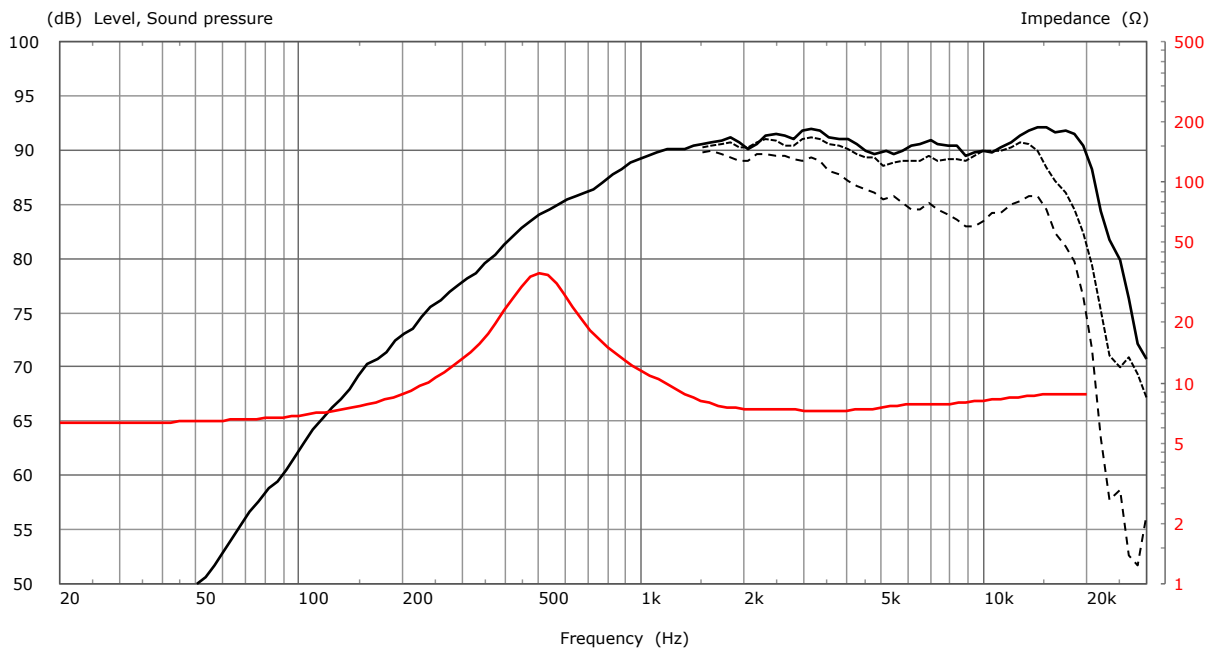

Frequency Response on IEC Baffle (DIN 45575) @ 25cm, normalized to SPL 1W,1m
Dotted line off-axis Frequency response at 30°,60° - Free Air Impedance
Measurement in Anechoic Chamber

General Specifications

Nominal Diameter	104 mm
Nominal Impedance	8 Ω
Rated Power AES ⁽¹⁾	25 W
Continuous Program Power ⁽²⁾	50 W
Rated Noise Power (IEC 60268-5) ⁽³⁾	120 W
Sensitivity @ 1W/1m ⁽⁴⁾	91.5 dB
Voice Coil Diameter	28 mm (1.1")
Voice Coil Winding Depth	2.7 mm
Magnetic Gap Depth	3.0 mm
Flux Density	1.43 T
Magnet Weight	92 g
Recommended Crossover Frequency	1.5 kHz

Thiele & Small Parameters⁽⁵⁾

Re	6.0 Ω	Fs	520 Hz
Qms	2.12	Qes	0.48
Qts	0.39	Mms	0.5 g
Cms	203 μm/N	Bxl	4.43 Tm
Vas	0.02 l	Sd	9.1 cm ²
ηo	0.67 %	Le (1kHz)	0.01 mH

Constructive Characteristics

Magnet	Neodymium
Voice Coil Winding Material	Aluminium Flat Wire
Voice Coil Former Material	Aluminium
Diaphragm	Treated Silk
Ferrofluid in Air Gap	No
Flange	Aluminium
Spare Part Code	ZH02800-8 SP

Mounting Information

Overall Diameter	104 mm
Baffle Cutout Diameter	73 mm
Mounting Holes	4 holes ø4,5 on ø92 mm
Total Depth	37.6 mm
Net Weight	0.4 kg

Included: sealing gasket, fixing screws, griff-nuts

(1) Rated Power measured with 2-hour test with pink noise signal, 6dB crest factor, loudspeaker in free air, power calculated on rated Zmin. (2) Power on Continuous Program is defined as 3dB greater than the Rated Power. (3) Rated Noise Power measured with 100 hours test pink noise, 6 dB crest factor IFC60268-5 filtering. (4) Measured at 1W, 1m in axis within the frequency range. (5) Thiele & Small parameters measured with laser system. (7) Drawing dimensions: mm.
Due to continuing product improvement, the features and the design are subject to change without notice.

pura passione